

Sustainable Management Practices of Japanese Companies in Pre-War Period from the Perspective of SDGs and ESG 3 : Kenkichi Kagami : Founder of Insurance Business in Japan

Hasegawa, Naoya / Takehara, Masaatsu

(出版者 / Publisher)

法政大学イノベーション・マネジメント研究センター

(雑誌名 / Journal or Publication Title)

法政大学イノベーション・マネジメント研究センター ワーキングペーパーシリーズ

(巻 / Volume)

222

(開始ページ / Start Page)

1

(終了ページ / End Page)

21

(発行年 / Year)

2020-01-31

Masaatsu Takehara and Naoya Hasegawa

Sustainable Management Practices of Japanese Companies
in Pre-War Period from the Perspective of SDGs and ESG

3

Kenkichi Kagami:
Founder of Insurance Business in Japan

January 31, 2020

No. **2 2 2**

Sustainable Management Practices of Japanese Companies in Pre-War Period from the Perspective of SDGs and ESG

3. Kenkichi Kagami: Founder of Insurance Business in Japan

Masaatsu Takehara and Naoya Hasegawa



(<https://www.ndl.go.jp/portrait/datas/458.html>)

1. Birth of non-life insurance-From merchant wisdom to marine insurance

Non-life insurance business in Japan began with the establishment of Tokio Marine Insurance (predecessor of Tokio Marine & Nichido Fire Insurance) in 1879 as a marine insurance company. In 1888, the Tokyo Fire Insurance (the company later became Yasuda Fire and Marine Insurance, currently Sompo Japan and Nihon Koa Insurance) was established.

Japan's non-life insurance developed through centering on marine insurance and fire insurance, however, nowadays, automobile insurance and automobile liability insurance are the main products triggered by post-war motorization.

Kenkichi Kagami is the person who made outstanding achievements in Japan's marine insurance history and created the foundation for the non-life insurance industry in Japan.

This chapter will try to reveal the characteristics of non-life insurance business and the process of its development in Japan by looking at the various activities of Kagami, who implemented management reforms that reflected the essence of non-life insurance business and created the foundation for the Japanese non-life insurance industry.

Before looking back on Kagami's business and his achievements, this chapter looks at the history of marine insurance which originated in Europe. A leading view about the origin of marine insurance was that it developed from adventure (maritime) "bottomry¹" in medieval Italy. Although there was a system called maritime bottomry even in ancient Greek and Roman periods, it developed as a risk sharing method for ships and cargo most of all in Italy, along with the development of Mediterranean trade, where the risk of navigation was relatively small.

Unlike today, it was a story of an era when the probability of accidents could not be statistically grasped. As the name bottomry shows, it was a high-risk, high-return contract, and interest on the principal was a high level of 24% to 36% per voyage.

In 1230, bottomry was stopped under the Pope's order to ban interest. However, with the development of Mediterranean trade, the need to diversify the risks associated with maritime transport increased, and marine insurance began with the wealthy people in northern Italy serving as insurance underwriters.

The history of non-life insurance at the time of its creation was the development history of marine insurance, however, marine insurance began in northern Italy during a period of commercial revolution in the 14th to 15th centuries, and then further developed in the 17th century with the rise

of the shipping industry centering on the United Kingdom, and it is said to have developed from the side businesses of merchants.

In the middle of the 17th century, many coffee shops were opened in London. The coffee shop Edward Lloyd ran (Lloyd's Coffee House) was later developed into a non-life insurance mecca. Lloyd gathered various information and provided it to coffee shop customers to attract them to the shop. Lloyd's coffee shop, which was capable of quickly gathering and providing necessary information ahead of its rivals, became a merchant's information base. It was there that valuable information led to business opportunities and risk avoidance was exchanged. The information collected by Lloyd was mostly related to shipping and trade, such as weather, ocean currents, and international affairs, and this kind of information attracted many shipowners, shippers, and insurance agents. In 1713, Lloyd's was founded by coffee shop patrons, and personal marine insurance was undertaken there².

In 1720, two companies, London Assurance and Royal Exchange Assurance, were established as licensed insurance companies. Since both companies were exclusively authorized to undertake marine insurance, other insurance companies in the corporate organization were completely unable to undertake marine insurance. Fortunately, as Lloyd's was an individual firm, it avoided the ban on underwriting, and since the licensed companies focused on marine insurance as well as fire insurance, Lloyd's grew to account for the majority of marine insurance in London. In the 19th century, many marine insurance companies were established in Western European countries in addition to the United Kingdom.

2. Birth of non-life insurance business in Japan

2.1 A similar system to non-life insurance

Trade lending was introduced to Japan by the Portuguese during the Shuin-sen trade era in the early 17th century³. It was called "nage-gane", and it was concluded between shippers and capitalists who had knowledge of trade and voyage, and the interest equivalent to insurance premiums was said to be 30-80% per voyage. However, "nage-gane" disappeared due to the Edo Shogunate's national isolation policy.

"Marine contract", which is a transaction similar to marine insurance, developed in Japan. This is a risk management method created by regular maritime transport, represented by the Higaki and

Barrel ships in the Edo period. The maritime contract was a transportation contract in which the shipping wholesaler or shipowner bore the damage if the cargo was damaged due to marine accidents, and the compensation cost for the damage was added to the fare. In other words, it was a system in which the shipping wholesaler or shipowner was the carrier and, at the same time, an underwriter for marine insurance. Until Tokio Marine Insurance was established in 1879, this contract played a risk management function in commercial transactions.

After the Meiji Restoration, Japan introduced marine insurance and fire insurance based on the modern insurance system, which was developed mainly in the United Kingdom. Yukichi Fukuzawa, who established Keio University, lectured on Western insurance systems (contract systems) at Keio. Insurance was incorporated into school education curriculums relatively early; in 1878, insurance was adopted as a specialized subject at Mitsubishi Commercial School, and in 1879, a lecture on marine insurance law was started at the University of Tokyo.

2.2 Establishment of Tokio Marine Insurance Company

In 1879, the Tokio Marine Insurance Company was established as Japan's first insurance company. The company's establishment dates back to a railway construction project between Tokyo and Aomori, which was envisioned in 1872 by an influential figure named Kaemon Takashima.

The promoters of this project were influential former daimyo's (Japanese feudal lords) who became kazoku (peerage) after the Meiji Restoration. However, the Meiji government decided that it was not suitable as a business of peerage because the new railway construction project required enormous financial resources and the business risk was high.

On the other hand, because the peerage needed business to achieve their economic independence, the Meiji government proposed a plan to sell off the existing railway (between Shinbashi and Yokohama), which had a more promising profit prospect, and a business union to work on this business was established with Eiichi Shibusawa as president. However, the implementation of the system of kinroku-kosai (hereditary pension bonds)⁴ had an impact on the finances of the kazoku peerage, and eventually the railway disposal project was withdrawn.

The kazoku who were involved in this project sought a new business to replace the railway business. They came up with three candidates, which were: (1) a marine insurance company, (2) the Stock Exchange, and (3) the construction of Nobiru Harbor at the estuary of Kitakami River. In those

days, the railway was undeveloped, so the center of logistics was maritime transportation. Shibusawa, who realized the need to bear the risk of marine transportation, insisted on the establishment of a marine insurance company, and commissioned a survey to Katsunori Masuda, who later became the chief operating officer of Tokio Marine Insurance Company.

In order to catch up with developed countries in Europe and the U.S.A., the Meiji government established a government-run model factory and promoted a policy for the encouragement of new industry. The development of non-life insurance in Japan cannot be discussed without noting this policy of industrial development. The increase in logistics with the development of industrialization promoted the growth of the shipping industry, and interest in marine insurance enhanced.

In the early Meiji era, Japan's international maritime logistics were dominated by American shipping companies. To counter this, a local kaiso (shipping) company was established in 1870 and the Japan Post Steamship Company was established in 1872; however, both companies lost business to foreign shipping companies. To deter foreign shipping companies, the Meiji government protected the Mitsubishi Company, led by Yataro Iwasaki, by granting the right of navigation in the waters near Japan, and eventually succeeded in eliminating the domination of foreign shipping companies.

Initially, Iwasaki's level of awareness about the importance of marine insurance was not necessarily high, however, as business with foreign countries expanded, he felt a strong need for marine insurance. In 1876, he applied to the Meiji government for the establishment of an insurance company and a license to operate the company. However, the application was rejected by opposition from Shigenobu Okuma, who was the Minister of Finance. Although no clear reason for rejecting the application was recorded, a conflict of interest in the establishment of an insurance company by a shipping company is considered to be one of the reasons for the rejection.

In 1878, a plan to establish the Tokio Marine Insurance Company started in full-scale with the aim to raise capital from kazoku (peerage). Eiichi Shibusawa, the actual leader of this project, requested Iwasaki to invest in the Tokio Marine Insurance Company. However, in order to avoid placing the new company under Mitsubishi's control, Shibusawa proposed to Iwasaki, the head of Mitsubishi, that the investment ratio of Mitsubishi be limited to 33% or less, and that the appointment of the company's officers be left to Shibusawa. Iwasaki felt strongly the needs of the insurance business and accepted this condition. Although the Meiji government rejected the 1876 application of an insurance business license, it granted the license to the 1878 application. Thus, the history of Tokio

Marine Insurance, the leading company in the non-life insurance industry in Japan, began.

3. The arrival of management crisis

3.1 Competition with rival companies

In 1893, the monopoly of Tokio Marine Insurance collapsed with the emergence of rival companies. Nippon Kairiku Insurance Co., Ltd., Teikoku Marine Insurance Co., Ltd. (a part of Yasuda Fire & Marine Insurance's predecessor), and Osaka Insurance Co., Ltd. (predecessor of Sumitomo Marine & Fire Insurance) were established one after another. In addition, the Tokyo Fire Insurance Company (a part of Yasuda Fire & Marine Insurance's predecessor) was established in 1887 as a specialized fire insurance company, followed by the Meiji Fire Insurance Company (a part of the Tokio Marine & Fire Insurance's predecessor), and the Japan Fire Insurance Company. For the Japanese non-life insurance industry in the Meiji period, companies specializing in marine insurance and companies specializing in fire insurance had their respective businesses. It was in 1914 that the Tokio Marine Insurance Company began its fire insurance business in addition to marine insurance.

At the time of establishment, Tokio Marine Insurance's main business territories were Tokyo, Osaka, Hokkaido, Niigata, Toyama, Ishikawa and Fukui. In these areas, the company undertook insurance contracts for the transportation of goods such as rice and dried-pressed boiled herring (used as fertilizer). It was also fortunate for Tokio Marine Insurance that it was a business practice to contract insurance on trades between domestic remote locations. Until its competitors entered into the market, Tokio Marine Insurance was able to maintain a high insurance premium as the only insurance company in Japan that handled marine insurance.

However, the emergence of Nippon Kairiku Insurance Co., Ltd., led by Naoharu Kataoka⁵, threatened the monopoly of Tokio Marine Insurance. Both companies had almost the same business areas and insurance products, so the two companies fought a fierce battle to gain customers. In addition, with the establishment of Teikoku Marine Insurance, the dumping of insurance premiums became common under the names of "return for no claim" or "return at term end". Intense price competition was not suitable for insurance businesses that required public benefit. However, this fierce competition also had an aspect that competition between companies over the acquisition of insurance contracts promoted understanding of risk and insurance philosophy.

3.2 Special characteristics of non-life insurance management

Due to the emergence of domestic competitors and the worsening balance of overseas sales in the U.K., Tokio Marine Insurance's business condition rapidly deteriorated. The failure of the insurance business in the U.K. was due to managers' poor understanding of the uniqueness of insurance management. Here, it is important to review the characteristics of accounting for non-life insurance business, which is an essential part of insurance business.

In non-life insurance management, the period of insurance contracts does not necessarily match the accounting period for calculating profit and loss. For example, for accidents that occurred during the current fiscal year, insurance payments may be paid during the current fiscal year, or payments may be delayed to the next fiscal year.

Figure 1 Insurance claim payment

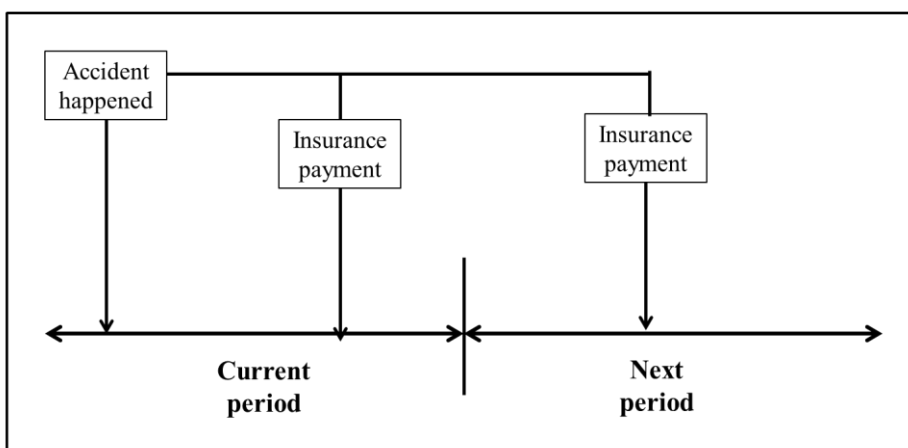

(Source) Created by the author based on Kogure [2010], page 107

If a loss is accounted for only insurance claims paid during the current fiscal year, and the insurance payments to be paid in the next fiscal year are not included in the current loss, it will not accurately reflect the profits and losses of the insurance company.

The profit and loss settlement and profit appropriation methods adopted by Tokio Marine Insurance divided all revenues into premium revenues and capital revenues, and operating income obtained by subtracting expenses from insurance revenues were spent on executive bonuses and reserves. Capital revenue was given to shareholders as dividends, and this method was called the "genkei" calculation method. It was a method of settling accounts in which only claims paid during

the current period were recorded as a loss and claims to be paid in the next period were not recognized.

Due to the large deficit in U.K. business and the slowdown in insurance premium revenues in the domestic market, Tokio Marine Insurance fell to no dividends in the second half of 1895. However, from the second half of 1891 to the first half of 1894, the company paid a high dividend (16%). The Meiji government welcomed a rather high dividend rate without questioning the Tokio Marine Insurance's settlement method. Their high profit was a virtual image created by an accounting method that did not accurately reflect the actual state of profits and losses. The reason why such an apprehension of profits was overlooked was due to the lack of managers' knowledge about managing insurance business.

4. Kenkichi Kagami

4.1 History

In 1868, Kenkichi Kagami was born in Gifu City, Gifu Prefecture, as the second son of Shozo Kagami. In 1877, he moved to Tokyo due to his father's work, and in 1884, he graduated from the Tokyo Prefectural Junior High School (later Tokyo Prefectural Daiichi Junior High School) with excellent grades.

His father operated a shop selling tea leaves in Kyobashi, Tokyo after he retired from an organization called "Eki-Teiryō", which was in charge of postal and communications business. However, his father's amateur merchant business quickly became stuck. Although Shozo Kagami did not make enough money, he was eager to educate his children and did not stop the studies of Kenkichi and his brother Koichiro. As their family was not wealthy, the Kagami brothers did door-to-door sales while carrying tea boxes to help maintain the household.

Kenkichi Kagami had a strong will to go to school after graduating from junior high school. Among the three candidate schools, Tokyo Higher Commercial School, the Naval Academy, and the Army Academy (students did not have to pay tuition fees in these schools), he chose to go to the Tokyo Higher Commercial School (predecessor of Hitotsubashi University). Another reason why he decided to go to this school was because he had been good at English and arithmetic when he was in junior high school. At the Tokyo Higher Commercial School, he became a close friend of Hachisaburo Hirao⁶ (who later became managing director of Tokio Marine Insurance), Tetsuya Mizushima (who later became the president of Kobe High School of Commerce) and Naotaro

Shimono (who later became a professor of Tokyo University of Commerce).

In 1888, after graduating from Tokyo Higher Commercial School, Kagami started to work as a teacher at the Kyoto Prefectural Commercial School, where he taught book-keeping and commercial arithmetic. At that time, it was common for graduates of Tokyo Higher Commercial School, who did not join companies or banks, to find employment as local schoolteachers.

Kagami's reputation as a teacher was good, and if he had followed his teaching career, he might have risen to a high position such as principal. However, Kagami felt unsatisfied with the teacher life, and in 1890, he left the school and joined the Osaka Prefectural Commodity Display Office (predecessor of the Osaka Industrial Technology Laboratory) as an auditor.

The Osaka Prefectural Product Display Office introduced foreign buyers to domestic products and domestic companies. Kagami gained a good reputation for his high level of English communication skills, and many foreign buyers relied on him. Kagami's ability was highly regarded by Teigo Iba, then the president of Sumitomo Zaibatsu (industrial conglomerate), and Iba even asked Kagami to join Sumitomo. As Kagami had hopes to work at a trade-related job in the future, he read through many books on Western finance and economy that the Osaka Prefectural Commodity Display Office owned.

4.2 Joining Tokio Marine Insurance

Tokio Marine Insurance at that time was managed by Heigoro Soda from Mitsubishi Zaibatsu (industrial conglomerate) as director, and Katsunori Masuda as manager. Masuda was dispatched by Eiichi Shibusawa as a person who was familiar with non-life insurance business because he learned marine insurance at commercial school. However, both men were amateurs in running an insurance company. In order to reconstruct Tokio Marine Insurance, which fell into a management crisis, it was urgent to recruit talented personnel from outside of the company.

At such a time, Kagami was recommended by Jiro Yano, principal of the Tokyo Commercial School, to join Tokio Marine Insurance. Yano's younger sister was the wife of Takashi Masuda, the older brother of Katsunori Masuda, who was the manager at Tokio Marine Insurance. Probably the Masuda brothers asked Yano to introduce talented people to them.

In 1891, Kagami took the entrance examination of Tokio Marine Insurance. He was one of three candidates who took the exam, however, the result was that all three candidates failed. Kagami was

re-examined as he had outstanding English communication skills and he was hired as a clerk. He experienced various insurance-related work such as customer relations, book-keeping, and telegraphing to London, and in his third year, he was assigned to London. Kagami was singled out as a person to rebuild the insurance business in London.

5. Rebuilding insurance business in London

5.1 Going to the United Kingdom (1894-1898)

Kagami went to the U.K. twice in 1894-98 and 1898-99. He felt that the cause of the poor business performance in the U.K. was due to the time lag between the revenue of insurance premiums and occurrence of loss. The accounting method Tokio Marine Insurance adopted was called the “reserve for casualties” method. In this method, operating income and insurance money (loss) were calculated and accounted separately. In order to improve the shortcomings of this method, Kagami proposed that the settlement of operating revenue be delayed for 6 months and to use the revenue for insurance payments; however, this proposal was never adopted.

From 1882, the Liverpool Agency increased the number of requests for reverse exchange⁷ and it began to put pressure on Tokio Marine Insurance management. Management teams that lacked an essential understanding of insurance management also became aware of the importance of the matter. Shibusawa, who felt a sense of crisis, proposed that Kagami be dispatched to London to investigate the cause and plan for improvement. Director Hirago Shoda and general manager Katsunori Masuda agreed with this proposal, and it was officially decided to dispatch Kagami to the U.K. The future of Tokio Marine Insurance, which was an excellent company representing the Meiji era, was entrusted on the shoulders of a young employee who joined the company in the fourth year.

5.2 The conditions of U.K. insurance business

After arriving in London, Kagami started to investigate the actual conditions of the Liverpool Agency, whose loss ratio had deteriorated. He collected an old list of ships and tackled an enormous amount of work distinguishing the underwriting of ships and cargo since 1890. As a result, he discovered that there was a loss from the first year of operation in London and that insurance payments had increased since then. Kagami’s rigorous investigations gradually revealed the U.K. underwriting problems.

Underwriting means the acceptance of risk, and insurance companies generally select and contract high-quality projects with low risk. On the other hand, insurance companies sometimes do not refuse a high-risk case and underwrite it by charging a premium corresponding to the risk. The important point of the insurance business is to determine the risk inherent in the applied contract and to determine whether to collect insurance premiums commensurate with the risk.

The Liverpool Agency commissioned by Tokio Marine Insurance had problems with underwriting. The majority of insurance contracts underwritten by this agency were high-risk contracts rejected by U.K. insurance companies. Even if it was a high risk, if an agency undertook the insurance contract, the agency would receive a commission fee. Payment of insurance money was a loss for an insurance company, however, agency revenue was not impacted. Kagami revealed that the Liverpool Agency was undertaking high-risk insurance contracts to earn commissions.

Kagami prohibited the Liverpool Agency from underwriting insurance and commissioned the Geratri & Company in London. However, changing the agency alone did not improve the business balance in the U.K. Since Geratri & Company adopted the “genkei” calculation method, Kagami changed its insurance balance to a yearly calculation method and recalculated the balance. As a result, he discovered a loss from the first year of operation.

Kagami was convinced of the structural flaws of the genkei calculation method based on the results of his survey, and he strongly recommended Tokio Marine Insurance management to change to the annual calculation method, and as a result, they adopted the annual calculation method from 1899. This method was already widespread in Western countries.

The British maritime magazine "Fairplay" criticized Japanese insurance companies' creation of such a strange balance sheet, where all premium revenues were earned and losses were paid out from another reserve. The magazine pointed out that those Japanese insurance companies would eventually fail. Also, there was criticism in Japan that insurance companies adopted the genkei calculation method in order to realize a high dividend policy.

The deficiency of the genkei calculation method was that only operating expenses and insurance losses that incurred in the current fiscal year were deducted from the revenue of insurance premiums within a single fiscal year, and no underwriting reserves were assumed for the remaining period of the following fiscal year. It was an unreasonable method of calculating profit and loss, ignoring the unique characteristics of the insurance business. In addition, in order to pay dividends to shareholders,

regardless of the amount of operating revenue, the idea of separating capital revenue from the beginning had many problems from the viewpoint of safety. At that time, Tokio Marine Insurance was in severe financial difficulties due to continuous insurance payments. Kagami proposed that the Tokio Marine Insurance headquarters abolish the genkei calculation method and adopt a policy year calculation method that he had devised; however, he could not gain the understanding of the officers.

This calculation method is called policy year basis loss ratio. It calculates the final loss ratio by grasping all insurance payments for accidents that occurred in the current period against revenue of premiums during the current period, including all subsequent payments⁸.

In 1895, Katsunori Masuda and Heigoro Shoda went to the U.K. one after another. Kagami submitted his detailed report “Inspection Report on U.K. Insurance Business” to Masuda and Shoda. The problems he pointed out were summarized into two points: elimination of high-risk contracts through appropriate underwriting, and improvement of random sales by developing statistical data on various risks.

5.3 Enactment of insurance business law and change to annual calculation method

Change began with the government regulation for insurance companies. Although the laws and regulations relating to insurance business were stipulated in commercial law, there was a strong opinion within the government that insurance business should be supervised by a single legislation independent from commercial law. In 1896, the Investigation Committee of Codes resolved the following three points:

- (1) The special law concerning insurance companies shall be drafted after deciding the provisions of insurance under commercial law.
- (2) Until the special law is enacted, the insurance company is required to be a stock company, with the exception of mutual companies.
- (3) A mutual company also needs a government license.

In 1898, Kenta Yano, who was the manager of Kyosai Life Insurance of the Yasuda conglomerate, was hired by the Ministry of Agriculture and Commerce as an insurance officer and worked on drafting insurance business law. Insurance business law, which was enacted in 1899, abolished the

genkei calculation method and stipulated the introduction of a reserve system for insurance policy reserves. This provision played a major role in strengthening the insurance company's management base. When Kagami stayed in the U.K., he had interacted with Yano, who had been dispatched to Germany for life insurance research.

When Yano asked Kagami how the policy reserves in marine insurance should be managed, he answered that it was an incorrect practice to record the profit immediately after deducting the insurance money paid and general operating expenses from insurance premiums. The entire amount should be deferred and used for the insurance money to be paid in the second year⁹. Kagami's view was reflected in the policy reserve funding system stipulated in the Enforcement Rules of Insurance Business Law.

Tokio Marine Insurance adopted Kagami's proposal and worked on the disposal of loss and improvement of the settlement method. Its contents were: (1) the genkei calculation method was changed to the annual calculation method after June 1899, (2) perform a capital reduction, and (3) request a government subsidy.

As shown in Chart 3, the loss that Tokio Marine Insurance incurred as a result of the shift to the annual calculation method reached 647,835 yen. This loss was compensated by a government subsidy of 259,134 yen, a capital reduction of 375,000 yen, an increase of 2,770 yen in valuation of the Osaka branch building, and an increase in valuation of owned shares of 10,931 yen.

Table 1 Loss due to shift to annual calculation method

	FY1896 account	Amount(Yen)
①	Loss (January 1, 1897 to December 31, 1898)	502,713.796
②	Reserve at the end of 1896	560.943
③	Net loss (①-②)	502,152.853
	FY1897 account	
④	Total loss (January 1, 1897 to December 31, 1898)	14,094
⑤	Reserves to cover claims to be paid during the unexpired insurance period	142,496
⑥	Total (④ + ⑤)	156,590.631
⑦	Capital revenue for the second half of 1898	10,907.792
⑧	Net loss (⑥-⑦)	145,682.839
	Total losses in FY1896 and FY1897 (③ + ⑧)	647,835.692

(Source) Prepared by the author based on Tokio Marine Insurance [1979a] p.194.

In order to properly calculate profit and loss for the period, currently the loss ratio, called the earned basis loss ratio, is used as an indicator. This indicator is also used for management decisions as it is not affected by the increase or decrease in contracts but reflects insurance claims for accidents that occurred during the period.

Figure 3 Calculation formula for earned basis loss ratio

$$\text{Earned Basis Loss ratio} = \frac{\text{Insurance claims paid(Incurred Loss) + Reserve for current year-end} - \text{Reserve for previous year-end}}{\text{Earned premiums}} \times 100\%$$

(Source) Kogure [2010], P.108, Author revised

The insurance policy reserve at the end of the previous fiscal year is the sum of A paid in the current fiscal year and B paid in the next fiscal year (recorded as a policy reserve due to being unpaid at the end of the current fiscal year) (previous fiscal year reserve = A + B). Insurance claims paid during the period are the sum of A incurred in the previous period and C incurred in the current period (insurance money paid for the period = A + C). The insurance reserve at the end of the current period is the sum of B and D scheduled to be paid from the next period (the insurance reserve at the end of the current period = B + D). When the numerator is applied to the above formula, “(A + C) + (B + D) – (A + B) = C + D” is obtained, and [C + D] is recognized as the insurance money occurred in the current period.

Prior to the enforcement of insurance business law, Tokio Marine Insurance shifted to the annual calculation method, however, there were some insurance companies, such as Nihon Kairiku Insurance, that were forced to dissolve due to an increase in losses as a result of the revision of the calculation method.

Figure 4 Relationship between insurance claims paid and reserves for payment

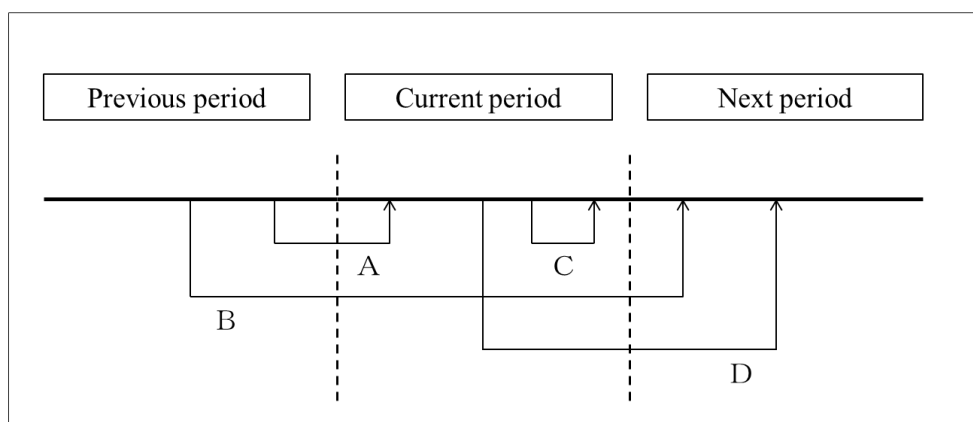

(Source) Kogure [2010], P.108, Author revised

5.4 Kagami's reform concept

In 1896, Kagami wrote the "Report and Recommendation on the U.K. Agency Business" and he made a proposal for management reform. He said that three elements were necessary in order for insurance business to succeed in the U.K.: (1) the company's own credit, (2) the company's supporters and sponsors, and (3) human resources.

Insurance companies in London were supported by people who had a deep understanding of underwriting, special knowledge, and experience. For business matters offered to insurance companies, conditions such as whether the risk is good or bad, whether the insurance company should undertake the risk or not, and what level of insurance premium rate the company needs to charge are finally judged by human beings.

After returning to Japan, Kagami thoroughly promoted human resource development at Tokio Marine Insurance based on his experience in the U.K. The biggest factor in the failure of insurance business in London was that Tokio Marine Insurance selected a partner agent with poor underwriting capability. At that time, Tokio Marine Insurance had no human resources who could understand and practice underwriting correctly.

Kagami returned to Japan once in April 1898 and went to the U.K. again in August of the same year. The purpose of his second visit to the U.K. was to close the Tokio Marine Insurance London branch and find a leading agency to commission the company's insurance business. In 1899, he decided to commission Willis Faber & Company as a new partner for Tokio Marine Insurance. Willis Faber & Company was a marine insurance broker that joined Lloyd's and it had the largest premium

revenue in the U.K. Furthermore, this company had sufficient experience and insight into various risks and did not give Kagami the impression that they ran the risk of undertaking a high-risk contract just to earn commissions.

Fortunately, Tokio Marine Insurance signed an agency contract with Willis Faber & Company and also succeeded in signing a comprehensive reinsurance contract for cargo insurance. Japanese non-life insurance companies in those days did not have comprehensive reinsurance contracts with foreign insurance companies, and as a result they had to conclude a reinsurance contract for each individual contract. If they undertook a large insurance contract, they had to pay a substantial amount of insurance money if an accident occurred. In this way, insurance companies always had factors that made their business results unstable. Therefore, minimizing the impact on financial performance, insurance companies need to have other insurance companies undertake some or all of the liabilities of the insurance contracts. This insurance contract is reinsurance, and reinsurance plays a major role for the stable management of insurance companies. Securing appropriate reinsurers in London, which could undertake Tokio Marine Insurance's risk, enabled them to actively expand business in Japan.

6. Kenkichi Kagami's management philosophy

In 1917, Kagami became managing director of Tokio Marine Insurance. He also served in many other important positions, including Chairman of Meiji Fire Insurance (1922), Chairman of Mitsubishi Marine and Fire Insurance (1925), Chairman of Mitsubishi Trust (1927), and President of Nippon Yusen Kaisha or NYK Line (1929). He also served as a member of Kizokuin (the House of Peers) (1930). Kagami also played an active part as an executive representing Mitsubishi Zaibatsu (industrial conglomerate) in those days.

Momosuke Fukuzawa, who was the husband of a daughter of Keio University founder Yukichi Fukuzawa, and was called the "King of Electric Power" for his success in the electric power business, described Kagami as a person who did not appeal to ordinary people but was a faithful servant of both the company and its shareholders.

Kagami was a typical office worker manager who joined Tokio Marine Insurance as an employee and climbed to the top of management by using his ability, and in that sense, he was a practitioner and a man of skill.

"The Times" in London reported the following article when the news of Kagami's death was

received:

“Along with his rare judgments, foresight and intelligence were integrated with his continuous efforts, courage, and patience, he was truly outstanding in any country and in every case of life.

Throughout his five years of staying in London, he was deeply influenced by the insurers' high morality and cautious behavior in the London insurance market, and while there he made remarkable success as an underwriter for the Tokio Marine Insurance Company. Throughout his life, Mr. Kagami maintained his philosophy of integrity, fairness and deliberateness, and that would satisfy both parties in any business deal.” (June 2, 1939 article)

Kenkichi Kagami also appeared on the cover page of the U.S.A. “TIME” magazine, following Heihachiro Togo and Emperor Showa^{1 0}. This also indicates that he was highly reliable overseas.

(Chart 5) Cover page of TIME magazine.



Source: Time magazine archive.

Kagami emphasized that the foundation of insurance company management is trust. He said that trust was not based on the wealth of a company's assets, but on the personality and behavior of the employees. In addition, he insisted that trust in business was an intangible asset, and this intangible asset enabled the accumulation of tangible assets; therefore, managers should make every effort to gain trust from customers and society.

His management view was well described in the following remark: “I believe that no other

business has to protect its trust, at the expense of everything, as the insurance business.”^{1 1}

Kagami was seen as a cold man because he had a clear mind and clear decision making based on strong-will. He never wasted company money. However, his essence was as an entrepreneur who had a selfless spirit, polished intelligence and tremendous willpower in complete harmony.

The words that Kagami cherished throughout his life were, "how to say 'NO' gently". Insurance contracts that were unwillingly underwritten often resulted in significant losses. Anyone who can say NO gently, so that the other party is convinced, is a person who can do anything. The words that Kagami cherished in his life reveal his warm personality in caring for others even though he was a tough businessperson.

The features of Kagami as a corporate manager were: (1) objective and rational decision-making based on actuarial analysis, (2) awareness of social responsibility as an insurance provider, and (3) a management philosophy based on trust. He investigated the cause of Tokio Marine Insurance's poor management by analyzing details of past data and he pushed the level of Japanese non-life insurance business to an international standard by introducing a modern accounting method. The truth the data told was the basis for his management judgment.

Kagami's attitude toward underwriting was a direct manifestation of social responsibility as an insurance provider and the spirit of service to policyholders. Insufficient analysis of the risks and expected damages may result in charging customers excessive premiums and not providing adequate compensation for damages. Recognizing that non-life insurance is closely linked to the socio-economic system, Kagami was fully aware that the responsibility of the insurer was fulfilled only by adequate underwriting.

In modern society, there is a growing interest in corporate social responsibility (CSR), and the central issue of CSR is who the company exists for. Corporate management is shifting to management that emphasizes the balance between social and economic returns to multi-stakeholders, including shareholders, in light of the fact that excessive profit-first policies have caused many corporate scandals.

Non-life insurance is responsible for mitigating business continuity risks and contributing to the sustainability of the economic system. Life insurance is responsible for mitigating risks of individual life continuity and contributing to the sustainability of social systems. The significance of insurance business is to support the sustainability of a socio-economic system composed of both individuals

and companies.

Kagami stated that trust is the foundation of insurance business. He said that profit, which is a tangible asset, is built by trust, which is an intangible asset. It takes an enormous amount of time for a company to gain trust from society. Trust of an insurance company is generated from the actions of its managers and employees, therefore, they have to continue efforts to gain trust.

In Japan, non-insurance payment by insurance companies in 2005 became a major social problem. Many insurance companies did not pay the insurance money that they should have, based on their insurance policies. Tokio Marine Insurance was among them and received a partial business suspension order from the Japanese Financial Services Agency on March 14, 2007 for reasons such as non-payment of insurance. With the revelation of a sloppy management system that neglected customers, the trust Tokio Marine Insurance had built up in the past collapsed in a moment. Managers of Japanese non-life insurance companies are required to return to the starting point of insurance business, as indicated by Kagami, and to make utmost efforts to restore lost trust.

In 1970, Kagami, who led the development of Japanese insurance business, was inducted into the International Insurance Hall of Fame at the same time as Kenta Yano. The International Insurance Hall of Fame aims to honor those who have made significant contributions to the development of insurance business. Kagami and Yano were the first Japanese to receive this honor.

In May 1939, Kenkichi Kagami ended his 71-year-old life while serving as the chairman of Tokio Marine Insurance. His 48 years of service for the company was exactly the history of the development of the Japanese non-life insurance industry. Kagami's business life was solely dedicated to Tokio Marine Insurance and this was in contrast to Hachisaburo Hirao, Kagami's sworn friend, who expanded his field of activities to the political and industrial world after leaving the Tokio Marine Insurance Company.

References

- Fukuzawa, Momosuke [1990] "Zaikai Jinbutsu Gakan (Personal view about businesspersons)" (Businesspeople Series) Tosho-shuppansha
- Fukuzawa, Yukichi and Yoshida, Kensuke [2008] "Western Travel Guide (Reprint Modern Japanese Literature)" National Literature Research Museum

Hasegawa, Naoya [2008] “Japanese Entrepreneurs” Bunshindo

Hasegawa, Naoya [2013] “History of financial business in Japan through entrepreneurial activities” Bunshindo

Kobayashi, Tadashi [1991] “The Biographies of Insurance Thinkers” Insurance Mainichi Shimbun

Kobayashi, Tadashi [2005] “Insurance Thought and Management Philosophy” Chikura Shobo

Japan Insurance Newspaper [1968] "History of Insurance in Japan" Japan Insurance Newspaper

Insurance Research Institute [1982] “History of Japanese Insurance Business (Overview edition) (Company edition Vo.1 and 2)” Insurance Research Institute

Insurance Research Institute "Insurance: Non-life Insurance Statistics"

Hoken Hyoron Sha [1973] “Directory of Insurance in Japan” Nihon Hoken Hyoron Sha

Inagaki, Suezaburo [1951] “” Mr. Kagami’s notes” and “Reports and Opinions during his stay in the UK”” Tokio Marine and Fire Insurance

Iwai, Ryotaro [1955] “The Biographies of Kenkichi Kagami and Takeo Kato” (The 9th volume, The Biographies of Japanese businesspersons) Toyoshokan

Kogure, Masakazu [2010] “Mathematics of Insurance-Life Insurance/Non-life Insurance/Pension” Insurance Mainichi Shimbun

Kojima, Hideki [2006] “Episode 11: Kenkichi Kagami” “Men’s twilight years” Nikkei

Suzuki, Sakae [1949] “Remembering Kenkichi Kagami” Kagami Memorial Foundation

TIME Editorial Department [1997] “Japan's Real Face seen by TIME” Yohan Shuppan

Tokio Marine and Fire Insurance [1964] " Eighty Year History of Tokio Marine"

Tokio Marine and Fire Insurance [1979a] "A hundred years history of Tokio Marine and Fire Insurance Co., Ltd."

Tokio Marine and Fire Insurance [1979b] "100 Years of Tokio Marine"

Unoki, Tadashi [1940] “Kenkichi Kagami” Showa Shobo

¹ Bottomry was a monetary loan agreement in which the borrower borrows money from ships or cargo as collateral. If the collateral was completely lost in a maritime accident, both the principal and interest would be relieved.

² The marine insurer based in Lloyd's Coffee House was called the Underwriters of Lloyd's Coffee House. In 1871, the Lloyd's Act was enacted, and it was reorganized into Lloyd's Insurance Association which had legal entity.

³ Shuin-sen is a ship that traded overseas with an overseas travel permit called Shuin-jo (a red stamp) issued by Japanese rulers from the end of the 16th century to the beginning of the 17th century.

⁴ Kinroku Kosai was the public bond issued for people in the class below aristocrats in compensation for the abolition of the Roku-rewarding system after the Meiji Restoration (Weblio: <https://ejje.weblio.jp/sentence/content/%E9%87%91%E7%A6%84%E5%85%AC%E5%82%B5>).

⁵ Naoharu Kataoka was involved in the establishment of Nippon Life Insurance in 1889 and he became president in 1904.

⁶ Hachisaburo Hirao became the managing director of Tokio Marine Insurance in 1917, after serving as the principal of Kobe Commercial School. He supported the management of Tokio Marine Insurance together with Kagami.

⁷ Reverse exchange is a way of settling a remittance. It was also called reverse remittance.

⁸ Kogure [2010], p.110

⁹ Inagaki [1951], p.83.

¹⁰ May 18, 1931 issue

¹¹ Inagaki [1951], p.57.



本ワーキングペーパーの掲載内容については、著編者が責任を負うものとします。

法政大学イノベーション・マネジメント研究センター
The Research Institute for Innovation Management, HOSEI UNIVERSITY

〒102-8160 東京都千代田区富士見 2-17-1
TEL: 03(3264)9420 FAX: 03(3264)4690
URL: <http://riim.ws.hosei.ac.jp>
E-mail: cbir@adm.hosei.ac.jp

(非売品)
禁無断転載