

# A monofilar spiral antenna and its array above a ground plane—formation of a circularly polarized tilted fan beam

NAKANO, Hisamatsu / YAMAUCHI, Junji / SHINMA, Yasuhiro

(出版者 / Publisher)

IEEE

(雑誌名 / Journal or Publication Title)

IEEE Transactions on Antennas and Propagation / IEEE Transactions on Antennas and Propagation

(号 / Number)

10

(開始ページ / Start Page)

1506

(終了ページ / End Page)

1511

(発行年 / Year)

1997-10

# A Monofilar Spiral Antenna and Its Array Above a Ground Plane—Formation of a Circularly Polarized Tilted Fan Beam

Hisamatsu Nakano, *Fellow Member, IEEE*, Yasuhiro Shinma, and Junji Yamauchi, *Member, IEEE*

**Abstract**—A monofilar spiral antenna is analyzed in the presence of a conducting plane reflector, using the method of moments. The circumference of the spiral antenna is chosen to be 2.3 wavelengths. A tilted beam of circular polarization is realized by superposing the fields from two active regions. The gain of the tilted beam is approximately 8 dB. The frequency bandwidths for 1-dB gain drop and 3-dB axial ratio criterions are 12% and 23%, respectively. An array consisting of the four monofilar spiral antennas is also analyzed, where the array element spacing is chosen to be 0.8 wavelength at a design frequency  $f_0$ . The input impedances of the four spirals are almost the same as the impedance of the single monofilar spiral antenna at  $f_0$ . The array radiates a tilted fan beam with a gain increase of approximately 6 dB from the gain of the single spiral antenna at  $f_0$ . The frequency bandwidth for a 3-dB axial ratio criterion is almost the same as that of the single spiral antenna.

**Index Terms**—Array antenna, moment method solutions, spiral antenna.

## I. INTRODUCTION

PATCH [1]–[3], loop [4], and helical antennas [5]–[8] have been used for satellite communication systems such as a global positioning system. The radiation from these antennas is circularly polarized (CP), forming an axial beam pattern or a conical beam pattern.

A planar array antenna forming a tilted CP fan beam in the elevation plane has also been receiving attention as a land mobile communication antenna. If the beam from the planar antenna is not tilted in the elevation plane (i.e., the antenna radiates a beam in the direction normal to the antenna plane), the antenna plane must be tilted to direct the beam toward a satellite [9]. It follows that the antenna needs a bulky space, losing advantages of the planar antenna structure.

This paper presents a CP radiation element with a tilted beam and its array radiating a tilted fan beam. The radiation element is made of a single wire composed of a curved section and a vertical section. The curved section is defined by the Archimedean spiral function, where the periphery of the outermost curved section is chosen to be more than two wavelengths at an operation frequency. Therefore, this radiation element is regarded as an extended version of the curl antenna [10] or a simplified version of the two-wire Archimedean spiral antenna [11].

There have been many investigations of the radiation characteristics of spiral antennas [12]–[19]. Consideration of tilted beam formation is found in [17]–[19]. In [17], an unbalanced mode current is superposed on a balanced mode current to obtain a tilted beam, while in [18], the round shape of a spiral antenna is transformed to the eccentric shape. These investigations in [17] and [18] have been made under the condition that the spiral antennas have two arms (in free-space without a conducting plane reflector). In contrast to these investigations, in [19] the tilted beam is investigated for the case of a multi-arm spiral antenna. Note that the feed systems for two- and multi-arm spiral antennas are complicated because a balun circuit or an excitation circuit consisting of power dividers and phase shifters is required for practical use.

The radiation element analyzed here (called the *monofilar spiral antenna*) has a simpler arm configuration and a simpler feed system than two- and multi-arm spirals. The monofilar spiral has a round shape. It does not require a balun circuit. Analysis of the monofilar spiral antenna is made in the presence of a conducting plane reflector (a ground plane) for practical use, using the method of moments [20], [21].

The monofilar structure without a balun circuit is useful, in particular, for fabrication of an array antenna composed of spirals. After investigating the radiation characteristics of the single monofilar spiral antenna [22], [23], this paper refers to the performance of an array antenna composed of the four monofilar spiral antennas [24]. It is found that the array antenna can radiate a tilted CP fan beam without losing the inherent radiation characteristics of the single monofilar spiral antenna.

## II. CONFIGURATION

Fig. 1 shows the configuration and coordinate system of a monofilar spiral antenna. The antenna arm, made of a wire of radius  $\rho$ , is composed of a vertical section of length  $h$  and a curved section defined by the Archimedean spiral function. The distance  $r$  from the center  $o'$  to the point on the arm is given by  $a_{sp}\phi_w$ , where  $a_{sp}$  is the spiral constant and  $\phi_w$  is the winding angle starting at  $\phi_{st}$  and ending at  $\phi_{end}$ . The antenna is backed by a conducting plane reflector (a ground plane of infinite extent) and fed from a coaxial line.

To obtain a tilted beam, the outermost periphery (circumference) of the curved section must be more than two wavelengths. The tilted beam is obtained by superposing

Manuscript received March 7, 1997.  
The authors are with the College of Engineering, Hosei University, Koganei, Tokyo 184, Japan.

Publisher Item Identifier S 0018-926X(97)07219-0.

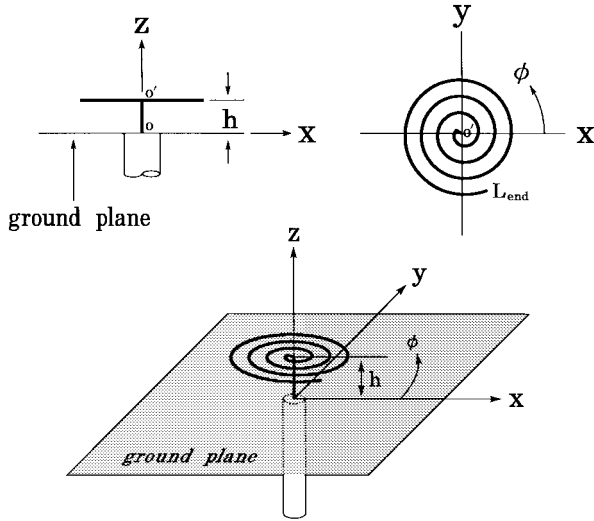

Fig. 1. Configuration and coordinate system of a monofilar spiral antenna.

radiation field  $F_1$  on radiation field  $F_2$ , where  $F_1$  is the radiation field from the first active region of an approximately one wavelength circumference on the spiral plane and  $F_2$  is the radiation field from the second active region of approximately two-wavelength circumference. The former  $F_1$  has approximately in-phase fields at two symmetrical points with respect to the  $z$  axis, whereas the latter  $F_2$  has a phase difference at these two symmetrical points. The phase relationship between  $F_1$  and  $F_2$  leads to a tilted beam.

Throughout this paper, the following parameters are used:  $\rho = 0.006\lambda_0$ ,  $h = 0.25\lambda_0$ ,  $a_{sp} = 0.0153\lambda_0/\text{rad}$ ,  $\phi_{st} = 2.6$  rad, and  $\phi_{end} = 24.0$  rad, where  $\lambda_0$  is the wavelength at a test (design) frequency of  $f_0$ . The maximum circumference, defined as  $C = 2\pi a_{sp}\phi_{end}$ , is  $2.3\lambda_0$ , corresponding to a diameter of  $0.73\lambda_0$ . Note that the diameter of the spiral is chosen to be less than  $\lambda_0$  for suppressing grating lobes in an array antenna. Also note that a conventional two-wire spiral antenna whose maximum circumference is  $2.3\lambda_0$  does not operate as a CP radiator, provided that it is backed by a conducting plane reflector [25].

For confirmation of analysis, experiment is carried out at  $f_0 = 6$  GHz.

### III. MONOFILAR SPIRAL ANTENNA

A monofilar spiral antenna is numerically analyzed. The current distribution is determined using the method of moments [20], [21], where the piecewise sinusoidal functions are used for the expansion and weighting functions. The radiation characteristics, including the radiation pattern, gain, and input impedance, are calculated using the obtained current distribution.

Fig. 2 shows the current distribution  $I = I_r + jI_i$  at frequency  $f_0$ . The arm length from the feed point  $o$  to the arm end  $L_{end}$  is  $4.64\lambda_0$ . It is found that a traveling wave current flows with decay toward the arm end. The reflected current from the arm end is small, which leads to a constant antenna impedance performance over a wide frequency band, as shown later. The phase progression is close to that in free-space.

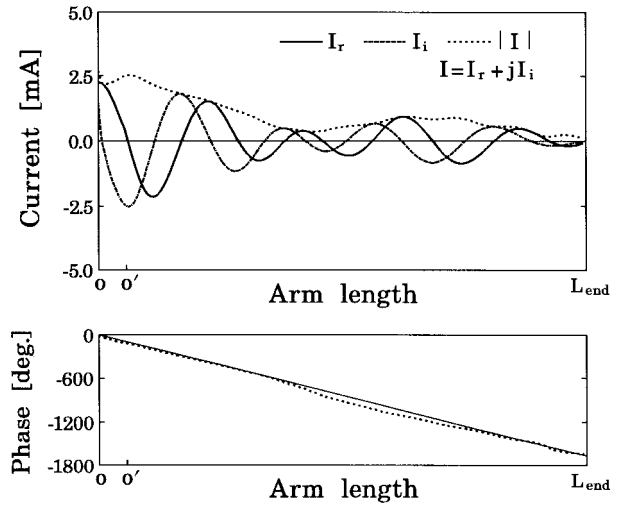

Fig. 2. Current distribution at frequency  $f_0$ .

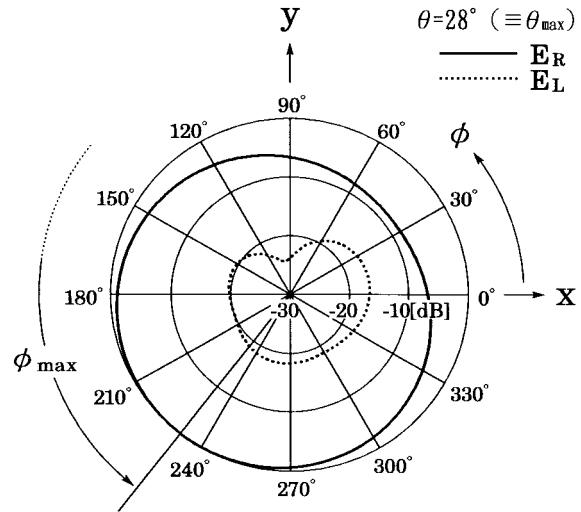

Fig. 3. Radiation pattern as a function of azimuth angle  $\phi$ .

The maximum radiation at frequency  $f_0$  occurs in a direction of  $(\theta, \phi) = (28^\circ \equiv \theta_{max}, 232^\circ \equiv \phi_{max})$ . The radiation pattern as a function of the azimuth angle  $\phi$  is shown in Fig. 3, where  $\theta = \theta_{max}$ . Note that the radiation field is decomposed into two components: a right-hand circularly polarized wave component ( $E_R$ ) and a left-hand circularly polarized wave component ( $E_L$ ).

The radiation pattern in the  $\phi = \phi_{max}$  plane at  $f_0$  is shown in Fig. 4(a), where the half-power beamwidth (HPBW) of the copolar component  $E_R$  is wide (approximately  $68^\circ$ ). Over this angle region, the radiation field is circularly polarized with an axial ratio of less than 3.2 dB, as shown in the axial ratio pattern Fig. 4(b).

Fig. 4(c) shows the beam cut in the  $x_1-z_1$  plane, where the  $x_1$  and  $z_1$  axes coincide with lines of  $\phi = \phi_{max} - 90^\circ$  and  $\theta = \theta_{max}$ , respectively, as shown in the inset. The HPBW in the  $x_1-z_1$  plane (approximately  $76^\circ$ ) is wider than that in the  $y_1-z$  plane. The axial ratio of less than 3 dB is obtained over a wide-angle region of approximately  $60^\circ$  around the  $z_1$  axis. This is shown in the axial ratio pattern [Fig. 4(d)].

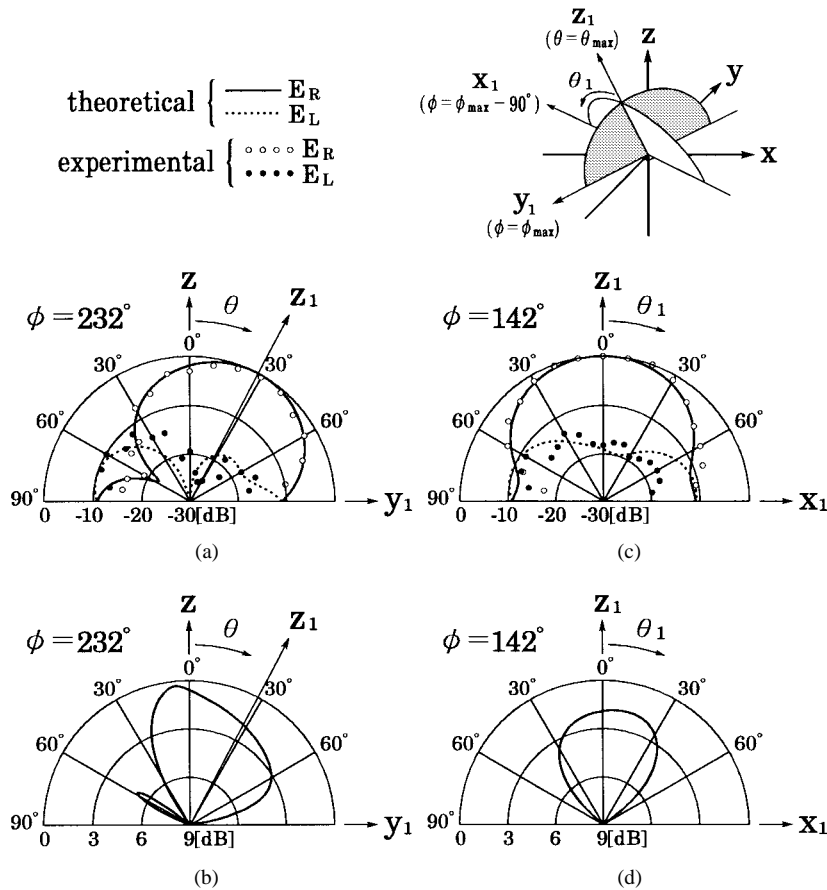

Fig. 4. Radiation and axial ratio patterns. (a) Radiation pattern in the  $\phi = \phi_{\max} = 232^\circ$  plane. (b) Axial ratio pattern in the  $\phi = \phi_{\max} = 232^\circ$  plane. (c) Radiation pattern in the  $\phi = \phi_{\max} - 90^\circ = 142^\circ$  plane. (d) Axial ratio pattern in the  $\phi = \phi_{\max} - 90^\circ = 142^\circ$  plane.

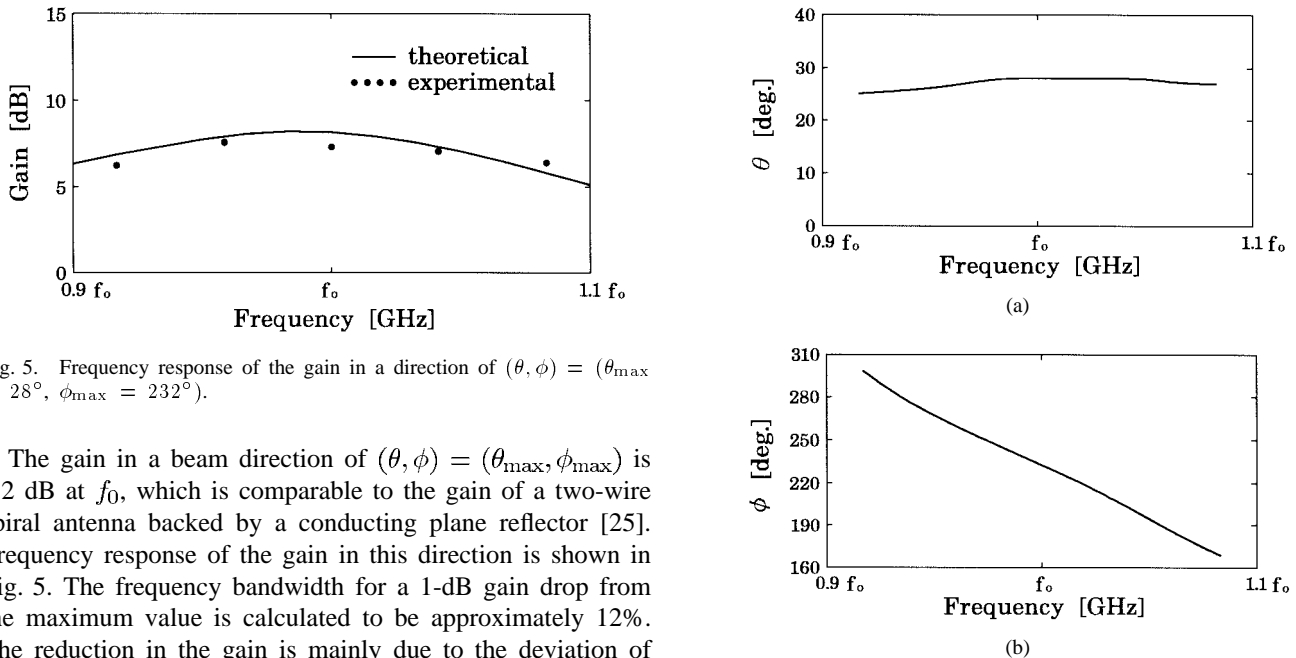

Fig. 5. Frequency response of the gain in a direction of  $(\theta, \phi) = (\theta_{\max}, \phi_{\max}) = 28^\circ, \phi_{\max} = 232^\circ$ .

The gain in a beam direction of  $(\theta, \phi) = (\theta_{\max}, \phi_{\max})$  is 8.2 dB at  $f_0$ , which is comparable to the gain of a two-wire spiral antenna backed by a conducting plane reflector [25]. Frequency response of the gain in this direction is shown in Fig. 5. The frequency bandwidth for a 1-dB gain drop from the maximum value is calculated to be approximately 12%. The reduction in the gain is mainly due to the deviation of the beam from a direction of  $(\theta, \phi) = (\theta_{\max}, \phi_{\max})$  with the change in frequency, as shown in Fig. 6.

The axial ratio in a beam direction of  $(\theta, \phi) = (\theta_{\max}, \phi_{\max})$  is shown in Fig. 7. The frequency bandwidth for a 3-dB axial ratio criterion is calculated to be approximately 23% ( $0.93f_0$ – $1.16f_0$ ). This bandwidth is slightly wider than that

Fig. 6. Beam direction as a function of frequency.

for the two-wire spiral backed by a conducting plane reflector (16% for a  $1.4\lambda_0$  circumference [25]).

By virtue of a traveling wave current with decay along the arm, the variation in the input impedance is small over a wide

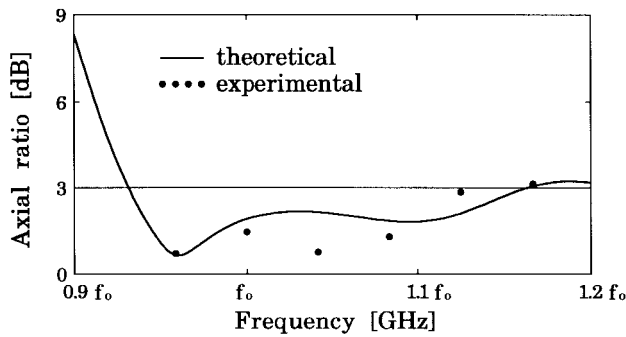

Fig. 7. Frequency response of the axial ratio in a direction of  $(\theta, \phi) = (\theta_{\max} = 28^\circ, \phi_{\max} = 232^\circ)$ .

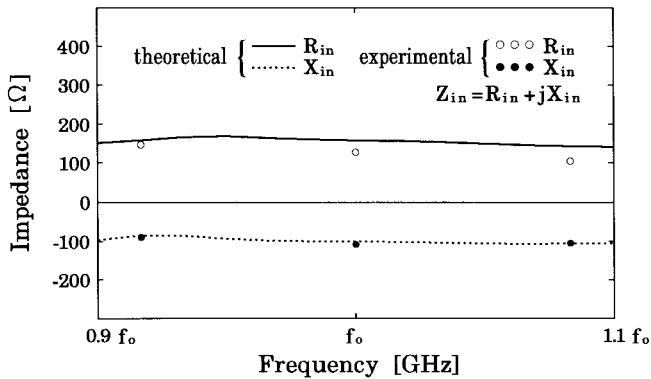

Fig. 8. Input impedance as a function of frequency.

frequency range. Fig. 8 shows the frequency response of the input impedance  $Z_{in} = R_{in} + jX_{in}$ . The resistance value of the input impedance is on the order of 150  $\Omega$ .

#### IV. ARRAY ANTENNA

The radiation characteristics of a monofilar spiral antenna have been revealed in Section III. In this section, an array antenna using the monofilar spirals is investigated. A tilted fan beam is realized.

Fig. 9 shows an array composed of the four monofilar spiral elements, where the distance between the elements is  $d = 0.8\lambda_0$ . To form a fan beam in the  $y$ - $z$  plane ( $\phi = 90^\circ$ ), each element is rotated around its center  $o$  by  $218^\circ (= 360^\circ - \phi_{\max} + 90^\circ)$  in the azimuth plane. After this rotation, the four elements are excited with the same amplitude and the same phase.

Fig. 10 shows the frequency response of the input impedance for each array element. The variation in the input impedance is small. The resistance values of the four elements at  $f_0$  range from 159  $\Omega$  to 165  $\Omega$  (only 6- $\Omega$  variation), with the reactance values ranging from  $-100 \Omega$  to  $-104 \Omega$  (only 4- $\Omega$  variation). These values are close to the input impedance of the single monofilar spiral antenna.

Fig. 11 shows the radiation pattern of the array at  $f_0$ , where a tilted fan beam is realized. The radiation pattern in the  $y$ - $z$  plane, Fig. 11 (a), is almost the same as Fig. 4(a). The beam tilt angle from the  $z$  axis,  $\theta_{\max 4}$ , is  $24^\circ$ , and the HPBW in the  $y$ - $z$  plane is  $70^\circ$ . The radiation pattern in the  $x$ - $z_4$

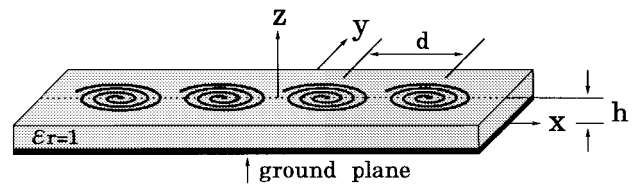

Fig. 9. An array composed of four monofilar spiral elements.

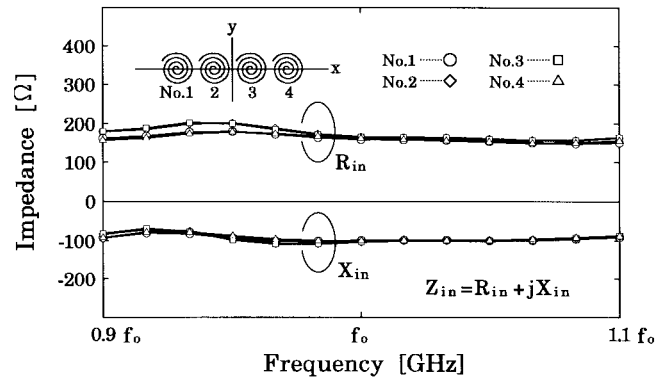

Fig. 10. Input impedances as a function of frequency for a four-element array antenna.

plane has a narrow HPBW due to array effects, where the  $z_4$  axis coincides with a line of  $\theta = \theta_{\max 4}$ , as shown in the inset of Fig. 11. The HPBW in the  $x$ - $z_4$  plane is  $16^\circ$ . The frequency dependency of the beam direction  $(\theta, \phi)$  is shown in Fig. 12.

Frequency responses for the gain and axial ratio are shown in Figs. 13 and 14, respectively. These values are observed at  $(\theta, \phi) = (\theta_{\max 4} \equiv 24^\circ, 90^\circ)$ . As expected, array effects increase the gain by approximately 6 dB at  $f_0$  from the gain of the single spiral element. The frequency bandwidth for a 1-dB gain drop criterion is calculated to be approximately 13%. The axial ratio of the array shows the same behavior as that of the single spiral antenna shown in Fig. 7. The 3-dB axial ratio criterion bandwidth for the array is calculated to be approximately 23%.

#### V. CONCLUSION

The radiation characteristics of a monofilar spiral antenna are investigated as a radiation element for land mobile communication systems where a tilted beam is required. The antenna circumference is chosen to be more than two wavelengths. The tilted beam is formed by superposing two radiation fields, making use of the phase difference between them.

The monofilar spiral has a traveling wave current with decay along the antenna arm. The spiral radiates a beam tilted by  $28^\circ$  from the antenna axis, whose HPBW in the elevation plane is  $68^\circ$  with a gain of 8.2 dB. The frequency bandwidth for a 3-dB axial ratio criterion is 23%.

To form a tilted fan beam with an increased gain, an array antenna composed of the four monofilar spiral elements is investigated. The array element spacing is chosen to be 0.8 wavelength at a design frequency  $f_0$ . The input impedances of the four spirals are almost the same as the impedance of

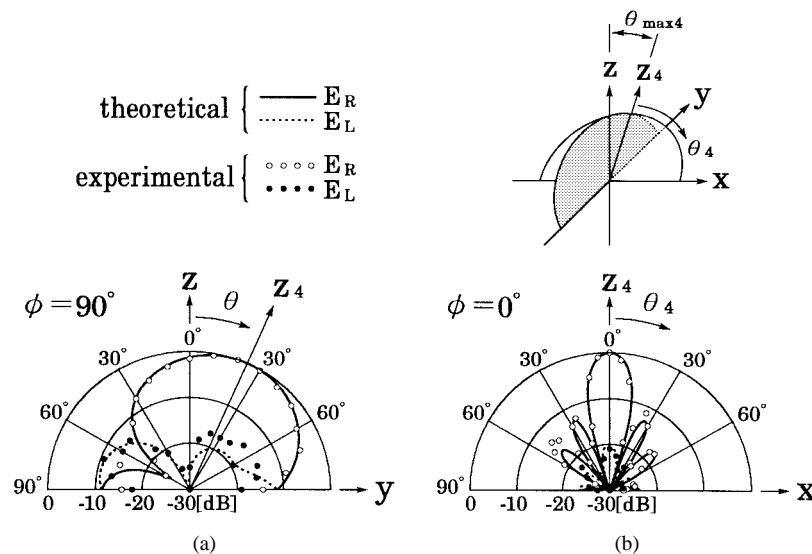

Fig. 11. Radiation pattern. (a)  $\phi = 90^\circ$  plane. (b)  $\phi = 0^\circ$  plane.

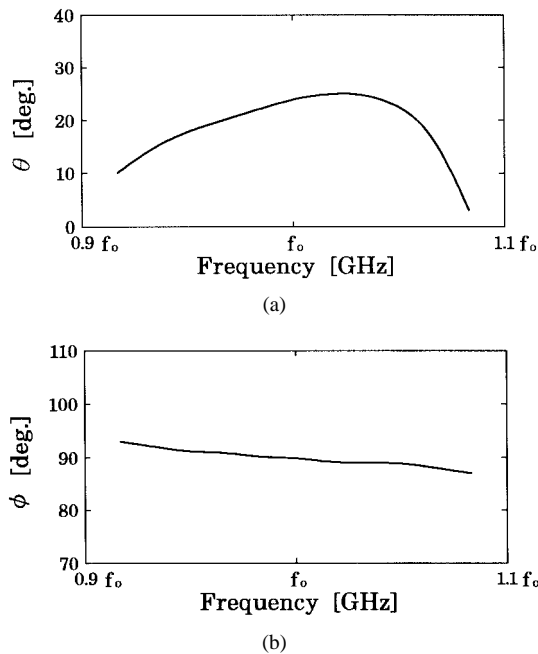

Fig. 12. Frequency response of the beam direction.

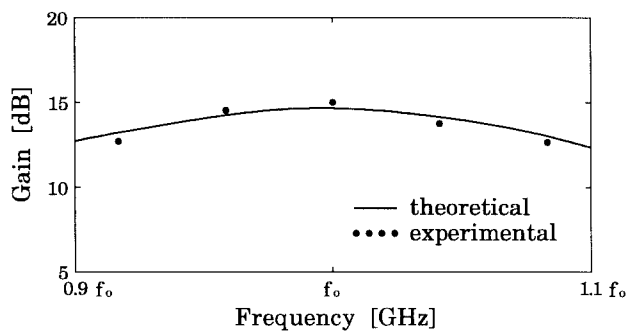

Fig. 13. Frequency response of the gain in a direction of  $(\theta, \phi) = (\theta_{\max 4} = 24^\circ, 90^\circ)$ .

the single monofilar spiral antenna at  $f_0$ . The array forms a fan beam of a HPBW of  $70^\circ$  in the elevation plane with a tilt angle of  $24^\circ$  from the antenna axis. The HPBW, tilt angle, and

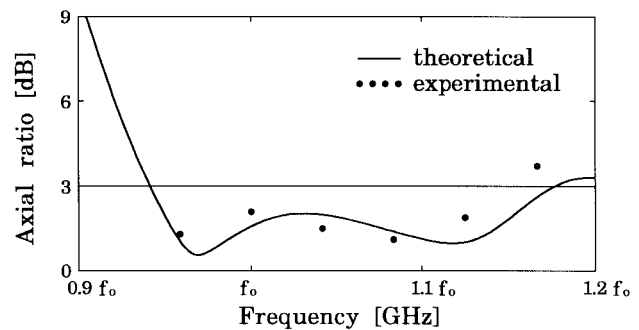

Fig. 14. Frequency response of the axial ratio in a direction of  $(\theta, \phi) = (\theta_{\max 4} = 24^\circ, 90^\circ)$ .

frequency bandwidth for a 3-dB axial ratio criterion are close to those for the single spiral antenna.

REFERENCES

- [1] J. Huang, "Circularly polarized conical patterns from circular microstrip antennas," *IEEE Trans. Antennas Propagat.*, vol. AP-32, pp. 991–994, Sept. 1984.
- [2] H. Nakano, K. Vichien, T. Sugiura, and J. Yamauchi, "Singly-fed patch antenna radiating a circularly polarized conical beam," *Electron. Lett.*, vol. 26, no. 10, pp. 638–639, 1990.
- [3] K. Hirasawa and M. Haneishi, Eds., *Introductory Analysis Design and Measurement of Small or Low-Profile Antennas*. Dedham MA: Artech House, 1992.
- [4] H. Nakano, H. Yoshida, and Y. Wu, "C-shaped loop antennas," *Electron. Lett.*, vol. 31, no. 9, pp. 693–694, 1995.
- [5] C. C. Kilgus, "Shaped-conical radiation pattern performance of the backfire quadrifilar helix," *IEEE Trans. Antennas Propagat.*, vol. AP-23, no. 3, pp. 392–397, May 1975.
- [6] H. E. King and J. L. Wong, "Characteristics of 1 to 8 wavelength uniform helical antennas," *IEEE Trans. Antennas Propagat.*, vol. AP-28, no. 2, pp. 291–296, Mar. 1980.
- [7] J. D. Kraus, *Antennas*, 2nd ed. New York: McGraw-Hill, 1988, ch. 7.
- [8] H. Nakano, Y. Saura, H. Mimaki, and J. Yamauchi, "Circularly polarized conical beam formation by backfire helical antennas," *Trans. IEICE*, vol. E74, no. 10, pp. 3246–3252, Oct. 1991.
- [9] K. Fujimoto and J. R. James, *Mobile Antenna Systems Handbook*. Norwood, MA: Artech House, pp. 436–438, 1994.
- [10] H. Nakano, S. Okuzawa, K. Ohishi, H. Mimaki, and J. Yamauchi, "A curl antenna," *IEEE Trans. Antennas Propagat.*, vol. 41, pp. 1570–1575, Nov. 1993.
- [11] J. A. Kaiser, "The Archimedean two-wire spiral antenna," *IRE Trans. Antennas Propagat.*, vol. AP-8, no. 3, pp. 312–323, May 1960.

- [12] H. Nakano, S. R. Kerner, and N. G. Alexopoulos, "The moment method solution for printed wire antennas of arbitrary configuration," *IEEE Trans. Antennas Propagat.*, vol. 36, pp. 1667–1674, Dec. 1988.
- [13] R. G. Corzine and J. A. Mosko, *Four-Arm Spiral Antennas*. Norwood, MA: Artech House, 1990.
- [14] J. J. H. Wong and V. K. Tripp, "Design of multioctave spiral-mode microstrip antennas," *IEEE Trans. Antennas Propagat.*, vol. 39, pp. 332–335, Mar. 1991.
- [15] P. E. Mayes, "Planar and other wide-angle logarithmic spirals over ground," *Electromagn.*, vol. 14, no. 3/4, pp. 329–362, July/Dec. 1994.
- [16] N. J. Champagne, II, J. T. Williams, and D. R. Wilton, "Analysis of resistively loaded, printed spiral antennas," *Electromagn.*, vol. 14, no. 3/4, pp. 363–395, July/Dec. 1994.
- [17] H. Nakano, "Analysis on beam deflection of spiral antenna," *Trans. IECE*, vol. 55-B, no. 12, pp. 693–694, Dec. 1972.
- [18] R. T. Gloutak Jr. and N. G. Alexopoulos, "On the theory of eccentric spiral antennas," in *IEEE APS Int. Symp.*, Chicago, IL, July 1992, pp. 2097–2100.
- [19] L. Shafai, "Design of multi-arm multi-mode spiral antennas for directional beams using equivalent array concept," *Electromagn.*, vol. 14, no. 3/4, pp. 285–304, July/Dec. 1994.
- [20] R. F. Harrington, *Field Computation by Moment Methods*. New York: Macmillan, 1968.
- [21] E. Yamashita, Ed., *Analysis Methods for Electromagnetic Wave Problems*. Norwood, MA: Artech House, 1996, vol. 2, ch. 3.
- [22] H. Nakano, S. Hashimoto, and J. Yamauchi, "CPW radiation characteristics of a single-wire spiral antenna with a small ground plane," in *Proc. IECE Gen. Conf.*, Tokyo, Japan, Mar. 1982, p. 88, vol. 635.
- [23] K. Hirose and H. Nakano, "A single-arm spiral antenna with a tilted beam," in *Symp. Antenna Technol. Appl. Electromagn.*, Montreal, ON, Canada, Aug. 1996, pp. 179–182.
- [24] H. Nakano, Y. Shinma, H. Mimaki, J. Yamauchi, and K. Hirose, "Fan beam formation using spiral array antennas," in *IEEE APS Int. Symp.*, Baltimore, MD, July 1996, pp. 1628–1631.
- [25] H. Nakano, K. Nogami, S. Arai, H. Mimaki, and J. Yamauchi, "A spiral antenna backed by a conducting plane reflector," *IEEE Trans. Antennas Propagat.*, vol. AP-34, pp. 791–796, June 1986.



**Yasuhiro Shinma** was born in Tokyo, Japan, on January 27, 1972. He received the B.E. and M.E. degrees from Hosei University, Tokyo, Japan, in 1995 and 1997, respectively.

He joined the Oki Electric Industry Co. Ltd., Tokyo, Japan, in 1997.

Mr. Shinma is a member of the Institute of Electronics, Information, and Communication Engineers of Japan.



**Junji Yamauchi** (M'85) was born in Nagoya, Japan, on August 23, 1953. He received the B.E., M.E., and Dr.E. degrees from Hosei University, Tokyo, Japan, in 1976, 1978, and 1982, respectively.

From 1984 to 1988, he served as a Lecturer at the Electrical Engineering Department of Tokyo Metropolitan Technical College, Japan. Since 1988, he has been a Faculty member of Hosei University, where he is now a Professor of electronic informatics. His research interests include circularly polarized antennas and optical waveguides.

Dr. Yamauchi is a member of the Optical Society of America and the Institute of Electronics, Information, and Communication Engineers of Japan.



**Hisamatsu Nakano** (M'75–SM'87–F'92) was born in Ibaraki, Japan, on April 13, 1945. He received B.E., M.E., and Dr.E. degrees in electrical engineering from Hosei University, Tokyo, Japan, in 1968, 1970, and 1974, respectively.

Since 1973, he has been a member of the faculty of Hosei University, Tokyo, Japan, where he is now a Professor of electronic informatics. Previously, he was a Visiting Associate Professor at Syracuse University, Syracuse, NY (March–September 1981), where he worked on numerical analysis of electromagnetic coupling between wires and slots. He was also a Visiting Professor at University of Manitoba, Canada (March–September 1986), researching numerical techniques for analysis of microstrip antennas and a Visiting Professor at University of California, Los Angeles (September 1986–March 1987), working on microstrip line antenna analysis. He has published more than 120 refereed journal papers and 80 international symposium papers on antennas and relevant problems. He is the author of *Helical and Spiral Antennas* (New York: Wiley, 1987) and he published the chapter "Antenna analysis using integral equations," in *Analysis Methods of Electromagnetic Wave Problems—Volume II* (Norwood, MA: Artech House, 1996). He is an Associate Editor of *IEEE Antennas and Propagation Magazine*. He developed a parabolic antenna using a backfire helical feed for direct reception of the broadcasting satellite TV programs (DBS) and two types of small indoor flat DBS antennas using novel elements—curled and extremely low-profile helical elements. His other developments include microstrip antennas for global positioning systems (GPS), personal handy telephone antennas, and small dual-polarization Cassegrain antennas for direct reception of communication satellite TV programs. His research interests include numerical methods for antennas, electromagnetic wave scattering problems, and light-wave problems.

Dr. Nakano was the recipient of an International Scientific Exchange Award from the Natural Sciences and Engineering Research Council of Canada in 1986. In 1987, he received the Best Paper Award of the Institute of Electrical Engineers Fifth International Conference on Antennas and Propagation. In 1994, he received the IEEE Antennas and Propagation Society Wheeler Award.